

NG-PON2 ONU Optical Transceiver XFP Module

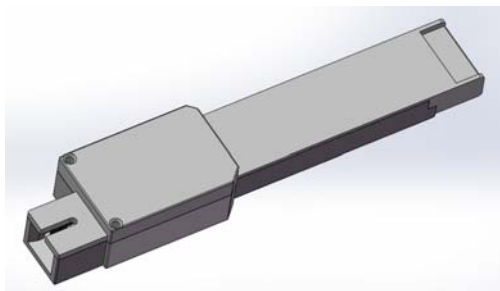

NG-PON2 ONU Optical Transceiver XFP Module

Absolute Maximum Ratings

Parameter	Symbol	Unit	Min	Max

Recommended Operating Conditions

Parameter	Symbol	Unit	Min	Typ	Max

Principle diagram

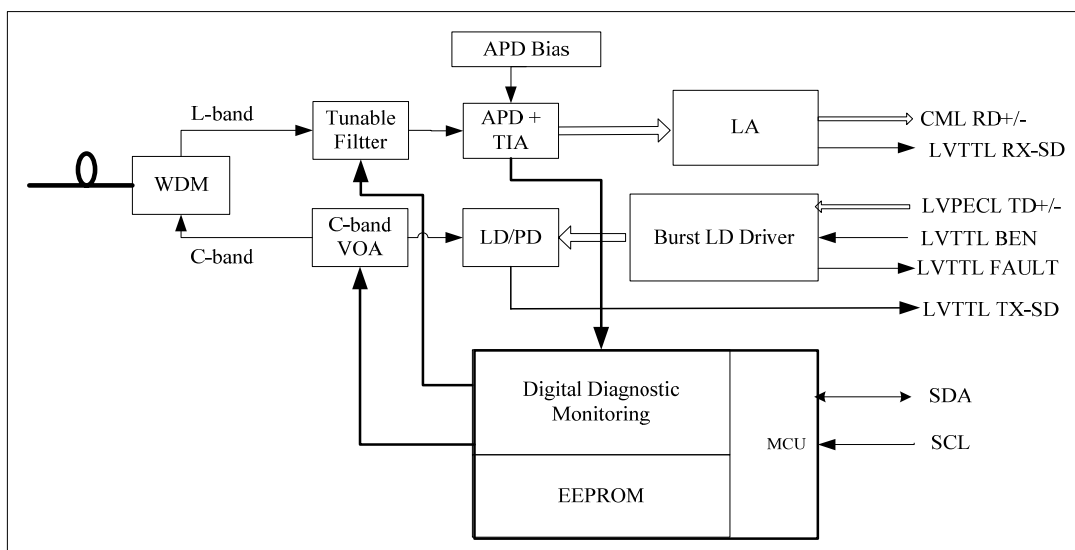

Note: VOA is optional.

